

APPLICATION:

JOB NAME:

QUANTITY: ITEM NO.

PRODUCT NAME:
DOUBLE PEDAL CONTROL VALVE WALL MOUNT

SPECIAL CONFIGURATION
 CHECK BASE MODEL AND OPTIONS

MODEL:
 3176

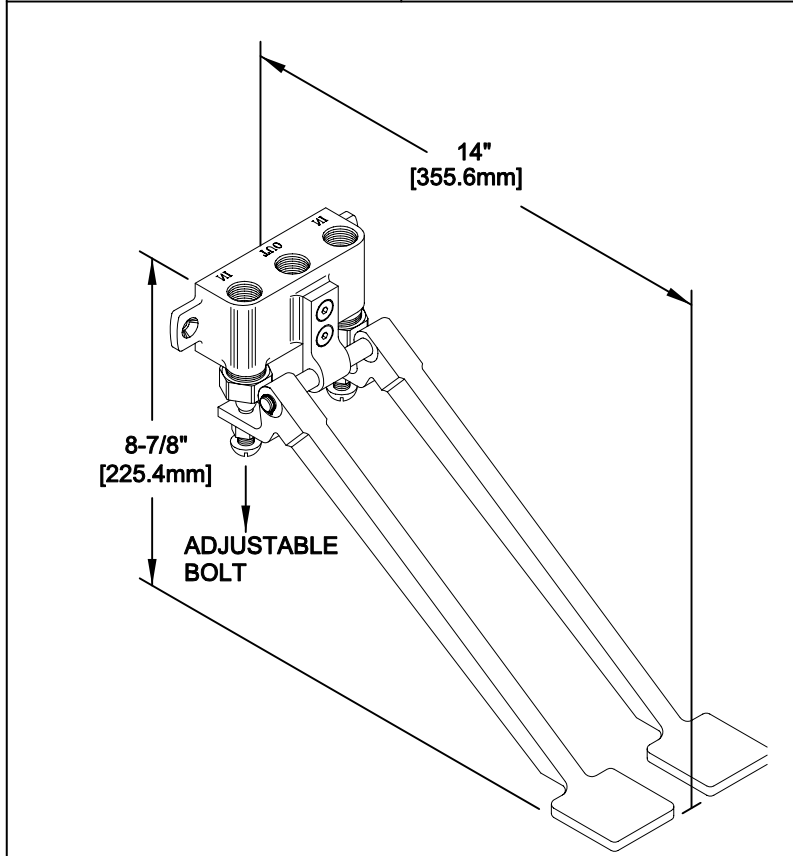

OPTIONS OR MODIFICATIONS:

SUPPLY LINES (24" OR 36") CIRCLE LENGTH

NIPPLES

ELBOWS

HANDLES (CROSS OR WRIST) CIRCLE STYLE

VANDAL RESISTANT KIT

OTHER _____

FEATURES

- * PEDAL ANODIZED ALUMINUM
- * CYLINDER CLOSERS WITH WATER FLOW
- * POLISHED CHROME

RECOMMENDED SETTINGS

- * 110°F AT 80 PSI

SYSTEM LIMITS

- * TEMP: 40°F MIN. TO 140°F MAX.
- * PRESSURE 200 PSI MAX. STATIC

SHIPPING WEIGHT

- * 4.0 LBS

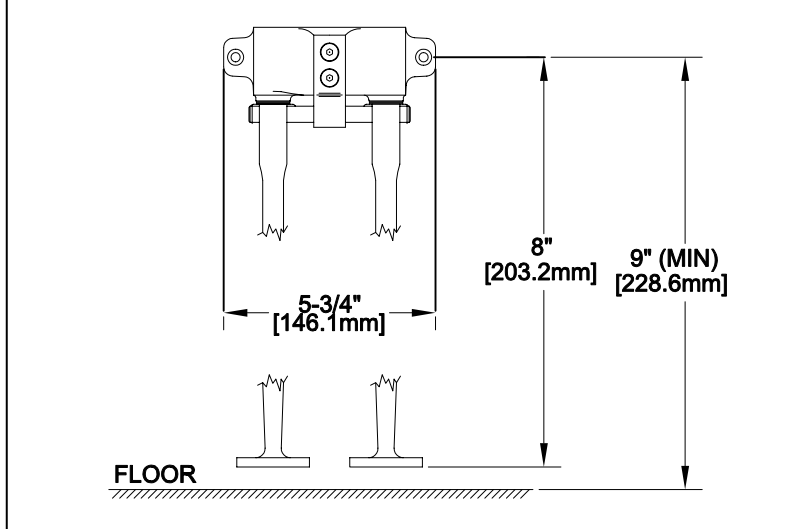

ROUGH-IN:

